



8080A/8080A-1/8080A-2 8-BIT N-CANNEL MICROPROCESSOR

- **TTL Drive Capability**
- **2 μ s (– 1:1.3 μ s, – 2:1.5 μ s) Instruction Cycle**
- **Powerful Problem Solving Instruction Set**
- **6 General Purpose Registers and an Accumulator**
- **16-Bit Program Counter for Directly Addressing up to 64K Bytes of Memory**
- **16-Bit Stack Pointer and Stack Manipulation Instructions for Rapid Switching of the Program Environment**
- **Decimal, Binary, and Double Precision Arithmetic**
- **Ability to Provide Priority Vectored Interrupts**
- **512 Directly Addressed I/O Ports**
- **Available in EXPRESS — Standard Temperature Range**
- **Available in 40-Lead Cerdip and Plastic Packages**

(See Packaging Spec. Order # 231369)

The Intel 8080A is a complete 8-bit parallel central processing unit (CPU). It is fabricated on a single LSI chip using Intel's n-channel silicon gate MOS process. This offers the user a high performance solution to control and processing applications.

The 8080A contains 6 8-bit general purpose working registers and an accumulator. The 6 general purpose registers may be addressed individually or in pairs providing both single and double precision operators. Arithmetic and logical instructions set or reset 4 testable flags. A fifth flag provides decimal arithmetic operation.

The 8080A has an external stack feature wherein any portion of memory may be used as a last in/first out stack to store/retrieve the contents of the accumulator, flags, program counter, and all of the 6 general purpose registers. The 16-bit stack pointer controls the addressing of this external stack. This stack gives the 8080A the ability to easily handle multiple level priority interrupts by rapidly storing and restoring processor status. It also provides almost unlimited subroutine nesting.

This microprocessor has been designed to simplify systems design. Separate 16-line address and 8-line bidirectional data busses are used to facilitate easy interface to memory and I/O. Signals to control the interface to memory and I/O are provided directly by the 8080A. Ultimate control of the address and data busses resides with the HOLD signal. It provides the ability to suspend processor operation and force the address and data busses into a high impedance state. This permits OR-tying these busses with other controlling devices for (DMA) direct memory access or multi-processor operation.

NOTE:

The 8080A is functionally and electrically compatible with the Intel 8080.

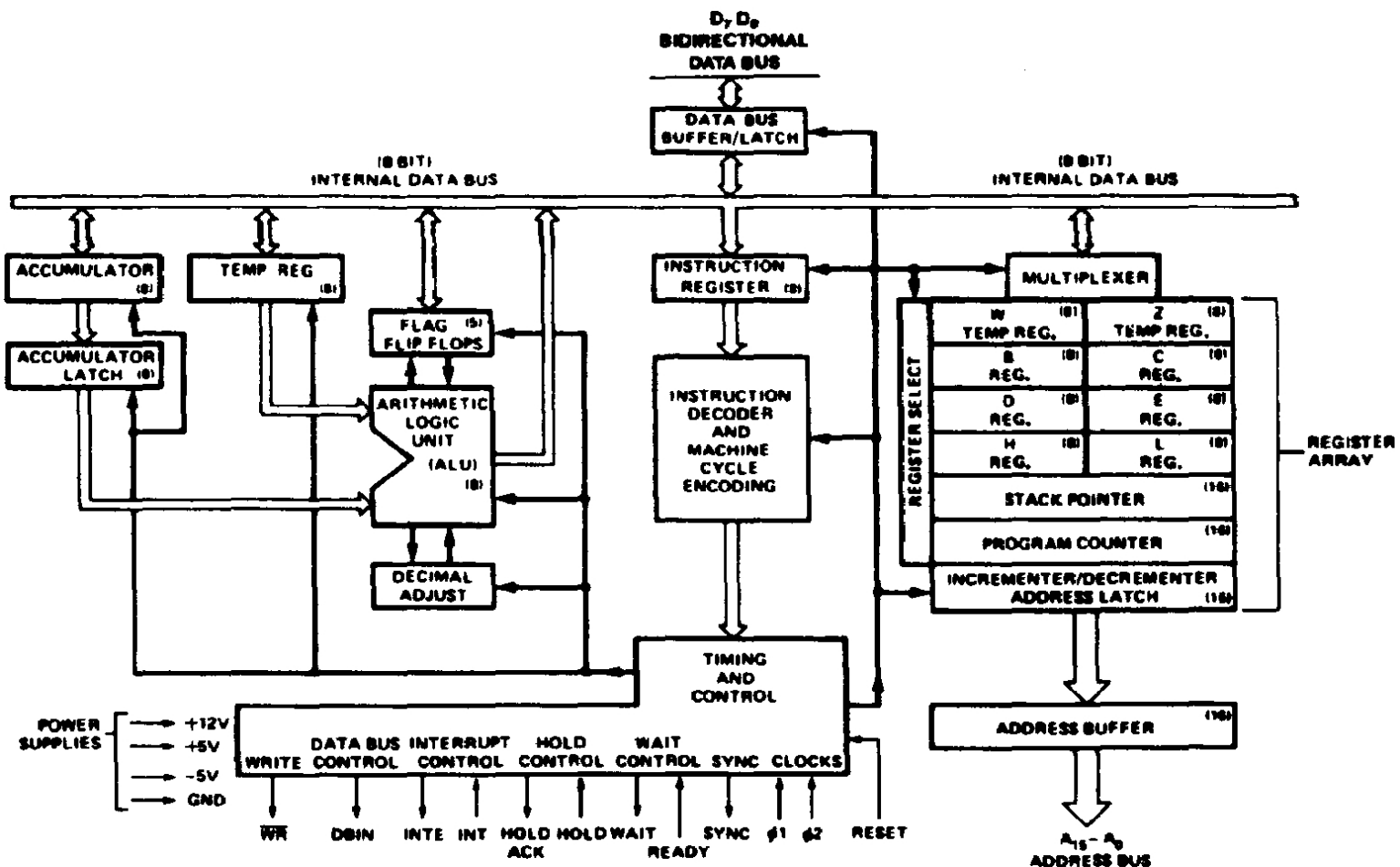

Figure 1. Block Diagram

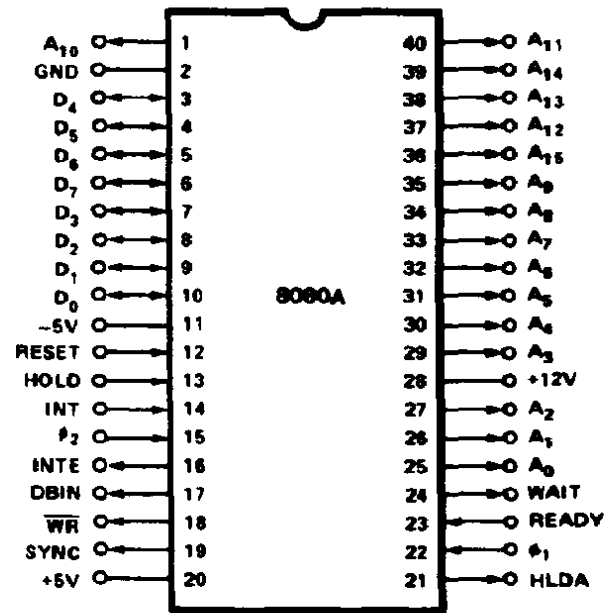

Figure 2. Pin Configuration

Table 1. Pin Description

Symbol	Type	Name and Function
A ₁₅ -A ₀	O	ADDRESS BUS: The address bus provides the address to memory (up to 64K 8-bit words) or denotes the I/O device number for up to 256 input and 256 output devices. A ₀ is the least significant address bit.
D ₇ -D ₀	I/O	DATA BUS: The data bus provides bi-directional communication between the CPU, memory, and I/O devices for instructions and data transfers. Also, during the first clock cycle of each machine cycle, the 8080A outputs a status word on the data bus that describes the current machine cycle. D ₀ is the least significant bit.
SYNC	O	SYNCHRONIZING SIGNAL: The SYNC pin provides a signal to indicate the beginning of each machine cycle.
DBIN	O	DATA BUS IN: The DBIN signal indicates to external circuits that the data bus is in the input mode. This signal should be used to enable the gating of data onto the 8080A data bus from memory or I/O.
READY	I	READY: The READY signal indicates to the 8080A that valid memory or input data is available on the 8080A data bus. This signal is used to synchronize the CPU with slower memory or I/O devices. If after sending an address out the 8080A does not receive a READY input, the 8080A will enter a WAIT state for as long as the READY line is low. READY can also be used to single step the CPU.
WAIT	O	WAIT: The WAIT signal acknowledges that the CPU is in a WAIT state.
\overline{WR}	O	WRITE: The \overline{WR} signal is used for memory WRITE or I/O output control. The data on the data bus is stable while the \overline{WR} signal is active low ($\overline{WR} = 0$).
HOLD	I	HOLD: The HOLD signal requests the CPU to enter the HOLD state. The HOLD state allows an external device to gain control of the 8080A address and data bus as soon as the 8080A has completed its use of these busses for the current machine cycle. It is recognized under the following conditions: <ul style="list-style-type: none"> • the CPU is in the HALT state. • the CPU is in the T₂ or T_W state and the READY signal is active. As a result of entering the HOLD state the CPU ADDRESS BUS (A₁₅-A₀) and DATA BUS (D₇-D₀) will be in their high impedance state. The CPU acknowledges its state with the HOLD ACKNOWLEDGE (HLDA) pin.
HLDA	O	HOLD ACKNOWLEDGE: The HLDA signal appears in response to the HOLD signal and indicates that the data and address bus will go to the high impedance state. The HLDA signal begins at: <ul style="list-style-type: none"> • T₃ for READ memory or input. • The Clock Period following T₃ for WRITE memory or OUTPUT operation. In either case, the HLDA signal appears after the rising edge of ϕ_2 .
INTE	O	INTERRUPT ENABLE: Indicates the content of the internal interrupt enable flip/flop. This flip/flop may be set or reset by the Enable and Disable Interrupt instructions and inhibits interrupts from being accepted by the CPU when it is reset. It is automatically reset (disabling further interrupts) at time T ₁ of the instruction fetch cycle (M ₁) when an interrupt is accepted and is also reset by the RESET signal.
INT	I	INTERRUPT REQUEST: The CPU recognizes an interrupt request on this line at the end of the current instruction or while halted. If the CPU is in the HOLD state or if the Interrupt Enable flip/flop is reset it will not honor the request.
RESET ¹	I	RESET: While the RESET signal is activated, the content of the program counter is cleared. After RESET, the program will start at location 0 in memory. The INTE and HLDA flip/flops are also reset. Note that the flags, accumulator, stack pointer, and registers are not cleared.
V _{SS}		GROUND: Reference.
V _{DD}		POWER: +12 ± 5% V.
V _{CC}		POWER: +5 ± 5% V.
V _{BB}		POWER: -5 ± 5% V.
ϕ_1, ϕ_2		CLOCK PHASES: 2 externally supplied clock phases. (non TTL compatible)

NOTE:

1. The RESET signal must be active for a minimum of 3 clock cycles.

ABSOLUTE MAXIMUM RATINGS*

Temperature Under Bias 0°C to +70°C
Storage Temperature -65°C to +150°C
All Input or Output Voltages with Respect to V_{BB} -0.3V to +20V
V_{CC} , V_{DD} and V_{SS} with Respect to V_{BB} -0.3V to +20V
Power Dissipation 1.5W

NOTICE: This is a production data sheet. The specifications are subject to change without notice.

*WARNING: Stressing the device beyond the "Absolute Maximum Ratings" may cause permanent damage. These are stress ratings only. Operation beyond the "Operating Conditions" is not recommended and extended exposure beyond the "Operating Conditions" may affect device reliability.

D.C. CHARACTERISTICS

$T_A = 0^\circ\text{C}$ to 70°C , $V_{DD} = +12\text{V} \pm 5\%$, $V_{CC} = +5\text{V} \pm 5\%$, $V_{BB} = -5\text{V} \pm 5\%$, $V_{SS} = 0\text{V}$; unless otherwise noted

Symbol	Parameter	Min	Typ	Max	Unit	Test Condition
V_{ILC}	Clock Input Low Voltage	$V_{SS} - 1$		$V_{SS} + 0.8$	V	
V_{IHC}	Clock Input High Voltage	9.0		$V_{DD} + 1$	V	
V_{IL}	Input Low Voltage	$V_{SS} - 1$		$V_{SS} + 0.8$	V	
V_{IH}	Input High Voltage	3.3		$V_{CC} + 1$	V	
V_{OL}	Output Low Voltage			0.45	V	} $I_{OL} = 1.9\text{ mA}$ on All Outputs, $I_{OH} = -150\ \mu\text{A}$.
V_{OH}	Output High Voltage	3.7			V	
$I_{DD(AV)}$	Avg. Power Supply Current (V_{DD})		40	70	mA	} Operation $T_{CY} = 0.48\ \mu\text{s}$
$I_{CC(AV)}$	Avg. Power Supply Current (V_{CC})		60	80	mA	
$I_{BB(AV)}$	Avg. Power Supply Current (V_{BB})		0.01	1	mA	
I_{IL}	Input Leakage			± 10	μA	$V_{SS} \leq V_{IN} \leq V_{CC}$
I_{CL}	Clock Leakage			± 10	μA	$V_{SS} \leq V_{CLOCK} \leq V_{DD}$
I_{DL}	Data Bus Leakage in Input Mode			-100 -2.0	μA mA	$V_{SS} \leq V_{IN} \leq V_{SS} + 0.8\text{V}$ $V_{SS} + 0.8\text{V} \leq V_{IN} \leq V_{CC}$
I_{FL}	Address and Data Bus Leakage During HOLD			+10 -100	μA	$V_{ADDR/DATA} = V_{CC}$ $V_{ADDR/DATA} = V_{SS} + 0.45\text{V}$

CAPACITANCE

$T_A = 25^\circ\text{C}$, $V_{CC} = V_{DD} = V_{SS} = 0\text{V}$, $V_{BB} = -5\text{V}$

Symbol	Parameter	Typ	Max	Unit	Test Condition
C_ϕ	Clock Capacitance	17	25	pF	$f_c = 1\text{ MHz}$
C_{IN}	Input Capacitance	6	10	pF	Unmeasured Pins
C_{OUT}	Output Capacitance	10	20	pF	Returned to V_{SS}

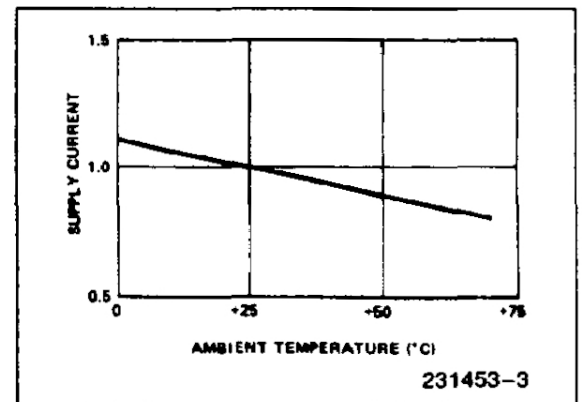

Typical Supply Current vs Temperature, Normalized
 $\Delta I_{Supply} / \Delta T_A = -0.45\% / ^\circ\text{C}$

A.C. CHARACTERISTICS (8080A) $T_A = 0^\circ\text{C to } 70^\circ\text{C}$, $V_{DD} = +12\text{V} \pm 5\%$, $V_{CC} = +5\text{V} \pm 5\%$,
 $V_{BB} = -5\text{V} \pm 5\%$, $V_{SS} = 0\text{V}$; unless otherwise noted

Symbol	Parameter	Min	Max	-1 Min	-1 Max	-2 Min	-2 Max	Unit	Test Condition
$t_{CY}^{(3)}$	Clock Period	0.48	2.0	0.32	2.0	0.38	2.0	μs	
t_r, t_f	Clock Rise and Fall Time	0	50	0	25	0	50	ns	
$t_{\phi 1}$	ϕ_1 Pulse Width	60		50		60		ns	
$t_{\phi 2}$	ϕ_2 Pulse Width	220		145		175		ns	
t_{D1}	Delay ϕ_1 to ϕ_2	0		0		0		ns	
t_{D2}	Delay ϕ_1 to ϕ_2	70		60		70		ns	
t_{D3}	Delay ϕ_1 to ϕ_2 Leading Edges	80		60		70		ns	
t_{DA}	Address Output Delay From ϕ_2		200		150		175	ns	$C_L = 100 \text{ pF}$
t_{DD}	Data Output Delay From ϕ_2		200		180		200	ns	
t_{DC}	Signal Output Delay From ϕ_1 or ϕ_2 (SYNC, WR, WAIT, HLDA)		120		110		120	ns	$C_L = 50 \text{ pF}$
t_{DF}	DBIN Delay From ϕ_2	25	140	25	130	25	140	ns	
$t_{DI}^{(1)}$	Delay for Input Bus to Enter Input Mode		t_{DF}		t_{DF}		t_{DF}	ns	
t_{DS1}	Data Setup Time During ϕ_1 and DBIN	30		10		20		ns	
t_{DS2}	Data Setup Time to ϕ_2 During DBIN	150		120		130		ns	
$t_{DH}^{(1)}$	Data Hold Time From ϕ_2 and DBIN	(1)		(1)		(1)		ns	
t_{IE}	INTE Output Delay From ϕ_2		200		200		200	ns	$C_L = 50 \text{ pF}$
t_{RS}	READY Setup Time During ϕ_2	120		90		90		ns	
t_{HS}	HOLD Setup Time During ϕ_2	140		120		120		ns	
t_{IS}	INT Setup Time During ϕ_2	120		100		100		ns	
t_H	Hold Time From ϕ_2 (READY, INT, HOLD)	0		0		0		ns	
t_{FD}	Delay to Float During Hold (Address and Data Bus)		120		120		120	ns	
t_{AW}	Address Stable Prior to WR	(5)		(5)		(5)		ns	
t_{DW}	Output Data Stable Prior to WR	(6)		(6)		(6)		ns	
t_{WD}	Output Data Stable From WR	(7)		(7)		(7)		ns	
t_{WA}	Address Stable From WR	(7)		(7)		(7)		ns	
t_{HF}	HLDA to Float Delay	(8)		(8)		(8)		ns	
t_{WF}	WR to Float Delay	(9)		(9)		(9)		ns	
t_{AH}	Address Hold Time After DBIN During HLDA	-20		-20		-20		ns	

A.C. TESTING LOAD CIRCUIT

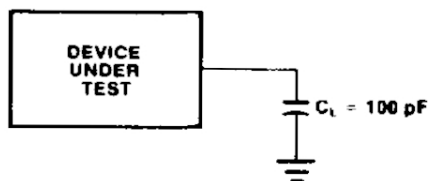

$C_L = 100 \text{ pF}$
 C_L Includes Jig Capacitance

WAVEFORMS

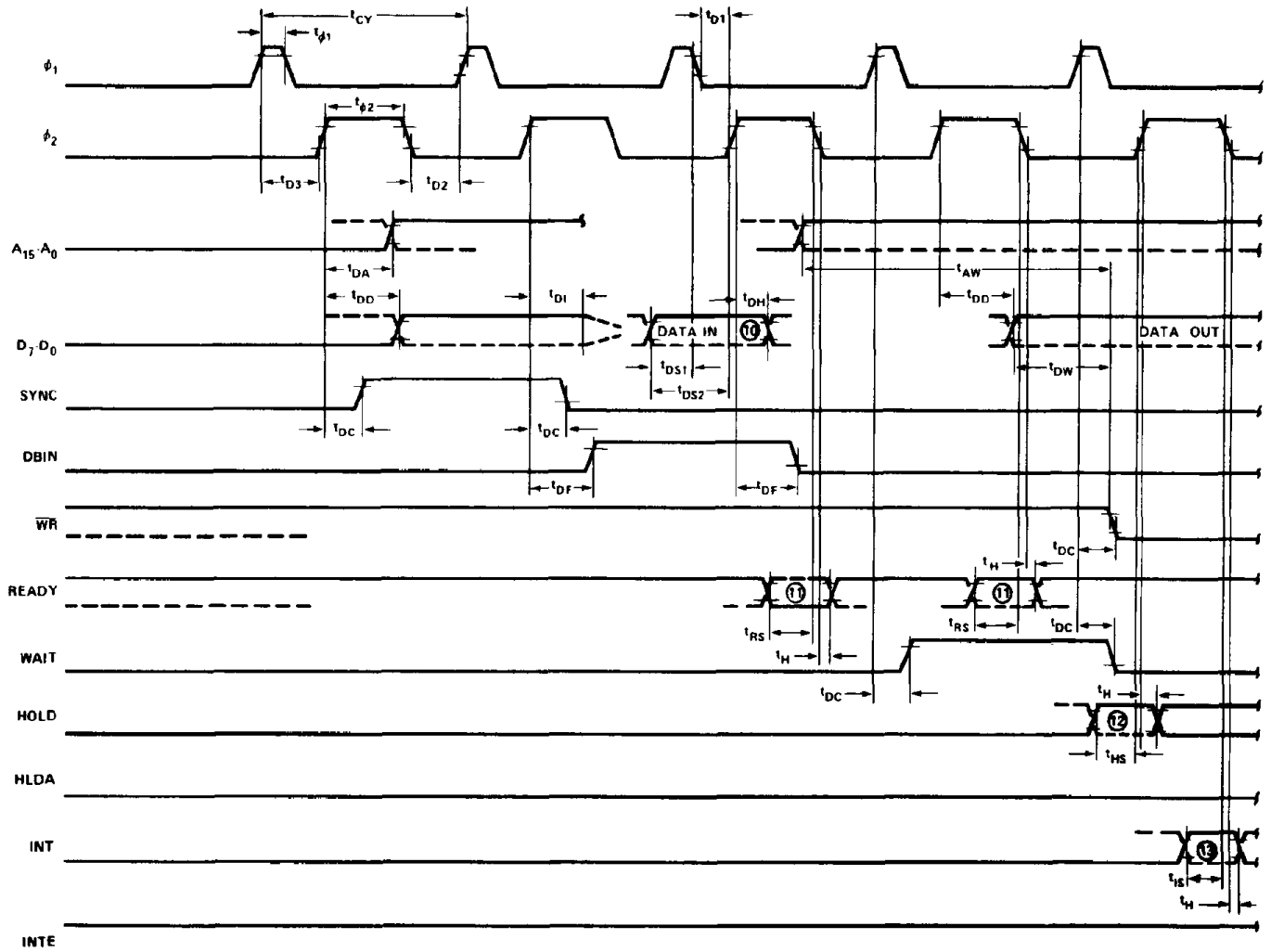

NOTE:
 Timing measurements are made at the following reference voltages: CLOCK "1" = 8.0V, "0" = 1.0V, INPUTS "1" = 3.3V, "0" = 0.8V; OUTPUTS "1" = 2.0V, "0" = 0.8V

INSTRUCTION SET

The accumulator group instructions include arithmetic and logical operators with direct, indirect, and immediate addressing modes.

Move, load, and store instruction groups provide the ability to move either 8 or 16 bits of data between memory, the six working registers and the accumulator using direct, indirect, and immediate addressing modes.

The ability to branch to different portions of the program is provided with jump, jump conditional, and computed jumps. Also the ability to call to and return from subroutines is provided both conditionally and unconditionally. The RESTART (or single byte call instruction) is useful for interrupt vector operation.

Double precision operators such as stack manipulation and double add instructions extend both the arithmetic and interrupt handling capability of the

8080A. The ability to increment and decrement memory, the six general registers and the accumulator is provided as well as extended increment and decrement instructions to operate on the register pairs and stack pointer. Further capability is provided by the ability to rotate the accumulator left or right through or around the carry bit.

Input and output may be accomplished using memory addresses as I/O ports or the directly addressed I/O provided for in the 8080A instruction set.

The following special instruction group completes the 8080A instruction set: the NOP instruction, HALT to stop processor execution and the DAA instructions provide decimal arithmetic capability. STC allows the carry flag to be directly set, and the CMC instruction allows it to be complemented. CMA complements the contents of the accumulator and XCHG exchanges the contents of two 16-bit register pairs directly.

Data and Instruction Formats

Data in the 8080A is stored in the form of 8-bit binary integers. All data transfers to the system data bus will be in the same format.

D ₇	D ₆	D ₅	D ₄	D ₃	D ₂	D ₁	D ₀
----------------	----------------	----------------	----------------	----------------	----------------	----------------	----------------

DATA WORD

The program instructions may be one, two, or three bytes in length. Multiple byte instructions must be stored in successive words in program memory. The instruction formats then depend on the particular operation executed.

One Byte Instructions

D ₇	D ₆	D ₅	D ₄	D ₃	D ₂	D ₁	D ₀
----------------	----------------	----------------	----------------	----------------	----------------	----------------	----------------

 OP CODE

TYPICAL INSTRUCTIONS

Register to register, memory reference, arithmetic or logical, rotate, return, push, pop, enable or disable Interrupt instructions

Two Byte Instructions

D ₇	D ₆	D ₅	D ₄	D ₃	D ₂	D ₁	D ₀
----------------	----------------	----------------	----------------	----------------	----------------	----------------	----------------

 OP CODE

Immediate mode or I/O instructions

D ₇	D ₆	D ₅	D ₄	D ₃	D ₂	D ₁	D ₀
----------------	----------------	----------------	----------------	----------------	----------------	----------------	----------------

 OPERAND

Three Byte Instructions

D ₇	D ₆	D ₅	D ₄	D ₃	D ₂	D ₁	D ₀
----------------	----------------	----------------	----------------	----------------	----------------	----------------	----------------

 OP CODE

Jump, call or direct load and store instructions

D ₇	D ₆	D ₅	D ₄	D ₃	D ₂	D ₁	D ₀
----------------	----------------	----------------	----------------	----------------	----------------	----------------	----------------

 LOW ADDRESS OR OPERAND 1

D ₇	D ₆	D ₅	D ₄	D ₃	D ₂	D ₁	D ₀
----------------	----------------	----------------	----------------	----------------	----------------	----------------	----------------

 HIGH ADDRESS OR OPERAND 2

For the 8080A a logic "1" is defined as a high level and a logic "0" is defined as a low level.

Table 2. Instruction Set Summary

Mnemonic*	Instruction Code (1)								Operations Description	Clock Cycles (2)
	D ₇	D ₆	D ₅	D ₄	D ₃	D ₂	D ₁	D ₀		
MOVE, LOAD, AND STORE										
MOV r ₁ ,r ₂	0	1	D	D	D	S	S	S	Move register to register	5
MOV M,r	0	1	1	1	0	S	S	S	Move register to memory	7
MOV r,M	0	1	D	D	D	1	1	0	Move memory to register	7
MVI r	0	0	D	D	D	1	1	0	Move immediate register	7
MVI M	0	0	1	1	0	1	1	0	Move immediate memory	10
LXI B	0	0	0	0	0	0	0	1	Load immediate register Pair B & C	10
LXI D	0	0	0	1	0	0	0	1	Load immediate register Pair D & E	10
LXI H	0	0	1	0	0	0	0	1	Load immediate register Pair H & L	10
STAX B	0	0	0	0	0	0	1	0	Store A indirect	7
STAX D	0	0	0	1	0	0	1	0	Store A indirect	7
LDAX B	0	0	0	0	1	0	1	0	Load A indirect	7
LDAX D	0	0	0	1	1	0	1	0	Load A indirect	7
STA	0	0	1	1	0	0	1	0	Store A direct	13
LDA	0	0	1	1	1	0	1	0	Load A direct	13
SHLD	0	0	1	0	0	0	1	0	Store H & L direct	16
LHLD	0	0	1	0	1	0	1	0	Load H & L direct	16
XCHG	1	1	1	0	1	0	1	1	Exchange D & E, H & L Registers	4
STACK OPS										
PUSH B	1	1	0	0	0	1	0	1	Push register Pair B & C on stack	11
PUSH D	1	1	0	1	0	1	0	1	Push register Pair D & E on stack	11
PUSH H	1	1	1	0	0	1	0	1	Push register Pair H & L on stack	11
PUSH PSW	1	1	1	1	0	1	0	1	Push A and Flags on stack	11
POP B	1	1	0	0	0	0	0	1	Pop register Pair B & C off stack	10
POP D	1	1	0	1	0	0	0	1	Pop register Pair D & E off stack	10
POP H	1	1	1	0	0	0	0	1	Pop register Pair H & L off stack	10
POP PSW	1	1	1	1	0	0	0	1	Pop A and Flags off stack	10
XTHL	1	1	1	0	0	0	1	1	Exchange top of stack, H & L	18
SPHL	1	1	1	1	1	0	0	1	H & L to stack pointer	5
LXI SP	0	0	1	1	0	0	0	1	Load immediate stack pointer	10
INX SP	0	0	1	1	0	0	1	1	Increment stack pointer	5
DCX SP	0	0	1	1	1	0	1	1	Decrement stack pointer	5
JUMP										
JMP	1	1	0	0	0	0	1	1	Jump unconditional	10
JC	1	1	0	1	1	0	1	0	Jump on carry	10
JNC	1	1	0	1	0	0	1	0	Jump on no carry	10
JZ	1	1	0	0	1	0	1	0	Jump on zero	10
JNZ	1	1	0	0	0	0	1	0	Jump on no zero	10
JP	1	1	1	1	0	0	1	0	Jump on positive	10

Mnemonic*	Instruction Code (1)								Operations Description	Clock Cycles (2)
	D ₇	D ₆	D ₅	D ₄	D ₃	D ₂	D ₁	D ₀		
JM	1	1	1	1	1	0	1	0	Jump on minus	10
JPE	1	1	1	0	1	0	1	0	Jump on parity even	10
JPO	1	1	1	0	0	0	1	0	Jump on parity odd	10
PCHL	1	1	1	0	1	0	0	1	H & L to program counter	5
CALL										
CALL	1	1	0	0	1	1	0	1	Call unconditional	17
CC	1	1	0	1	1	1	0	0	Call on carry	11/17
CNC	1	1	0	1	0	1	0	0	Call on no carry	11/17
CZ	1	1	0	0	1	1	0	0	Call on zero	11/17
CNZ	1	1	0	0	0	1	0	0	Call on no zero	11/17
CP	1	1	1	1	0	1	0	0	Call on positive	11/17
CM	1	1	1	1	1	1	0	0	Call on minus	11/17
CPE	1	1	1	0	1	1	0	0	Call on parity even	11/17
CPO	1	1	1	0	0	1	0	0	Call on parity odd	11/17
RETURN										
RET	1	1	0	0	1	0	0	1	Return	10
RC	1	1	0	1	1	0	0	0	Return on carry	5/11
RNC	1	1	0	1	0	0	0	0	Return on no carry	5/11
RZ	1	1	0	0	1	0	0	0	Return on zero	5/11
RNZ	1	1	0	0	0	0	0	0	Return on no zero	5/11
RP	1	1	1	1	0	0	0	0	Return on positive	5/11
RM	1	1	1	1	1	0	0	0	Return on minus	5/11
RPE	1	1	1	0	0	0	0	0	Return on parity even	5/11
RPO	1	1	1	0	0	0	0	0	Return on parity odd	5/11
RESTART										
RST	1	1	A	A	A	1	1	1	Restart	11
INCREMENT AND DECREMENT										
INR r	0	0	D	D	D	1	0	0	Increment register	5
DCR r	0	0	D	D	D	1	0	1	Decrement register	5
INR M	0	0	1	1	0	1	0	0	Increment memory	10
DCR M	0	0	1	1	0	1	0	1	Decrement memory	10
INX B	0	0	0	0	0	0	1	1	Increment B & C registers	5
INX D	0	0	0	1	0	0	1	1	Increment D & E registers	5
INX H	0	0	1	0	0	0	1	1	Increment H & L registers	5
DCX B	0	0	0	0	1	0	1	1	Decrement B & C	5
DCX D	0	0	0	1	1	0	1	1	Decrement D & E	5
DCX H	0	0	1	0	1	0	1	1	Decrement H & L	5
ADD										
ADD r	1	0	0	0	0	S	S	S	Add register to A	4
ADC r	1	0	0	0	1	S	S	S	Add register to A with carry	4
ADD M	1	0	0	0	0	1	1	0	Add memory to A	7
ADC M	1	0	0	0	1	1	1	0	Add memory to A with carry	7
ADI	1	1	0	0	0	1	1	0	Add immediate to A	7
ACI	1	1	0	0	1	1	1	0	Add immediate to A with carry	7
DAD B	0	0	0	0	1	0	0	1	Add B & C to H & L	10
DAD D	0	0	0	1	1	0	0	1	Add D & E to H & L	10
DAD H	0	0	1	0	1	0	0	1	Add H & L to H & L	10
DAD SP	0	0	1	1	1	0	0	1	Add stack pointer to H & L	10

Table 2. Instruction Set Summary (Continued)

Mnemonic*	Instruction Code (1) D ₇ D ₆ D ₅ D ₄ D ₃ D ₂ D ₁ D ₀	Operations Description	Clock Cycles (2)
SUBTRACT			
SUB r	1 0 0 1 0 S S S	Subtract register from A	4
SBB r	1 0 0 1 1 S S S	Subtract register from A with borrow	4
SUB M	1 0 0 1 0 1 1 0	Subtract memory from A	7
SBB M	1 0 0 1 1 1 1 0	Subtract memory from A with borrow	7
SUI	1 1 0 1 0 1 1 0	Subtract immediate from A	7
SBI	1 1 0 1 1 1 1 0	Subtract immediate from A with borrow	7
LOGICAL			
ANA r	1 0 1 0 0 S S S	And register with A	4
XRA r	1 0 1 0 1 S S S	Exclusive or register with A	4
ORA r	1 0 1 1 0 S S S	Or register with A	4
CMP r	1 0 1 1 1 S S S	Compare register with A	4
ANA M	1 0 1 0 0 1 1 0	And memory with A	7
XRA M	1 0 1 0 1 1 1 0	Exclusive Or memory with A	7
ORA M	1 0 1 1 0 1 1 0	Or memory with A	7
CMP M	1 0 1 1 1 1 1 0	Compare memory with A	7
ANI	1 1 1 0 0 1 1 0	And immediate with A	7
XRI	1 1 1 0 1 1 1 0	Exclusive Or immediate with A	7
ORI	1 1 1 1 0 1 1 0	Or immediate with A	7
CPI	1 1 1 1 1 1 1 0	Compare immediate with A	7

Mnemonic*	Instruction Code (1) D ₇ D ₆ D ₅ D ₄ D ₃ D ₂ D ₁ D ₀	Operations Description	Clock Cycles (2)
ROTATE			
RLC	0 0 0 0 0 1 1 1	Rotate A left	4
RRC	0 0 0 0 1 1 1 1	Rotate A right	4
RAL	0 0 0 1 0 1 1 1	Rotate A left through carry	4
RAR	0 0 0 1 1 1 1 1	Rotate A right through carry	4
SPECIALS			
CMA	0 0 1 0 1 1 1 1	Complement A	4
STC	0 0 1 1 0 1 1 1	Set carry	4
CMC	0 0 1 1 1 1 1 1	Complement carry	4
DAA	0 0 1 0 0 1 1 1	Decimal adjust A	4
INPUT/OUTPUT			
IN	1 1 0 1 1 0 1 1	Input	10
OUT	1 1 0 1 0 0 1 1	Output	10
CONTROL			
EI	1 1 1 1 1 0 1 1	Enable Interrupts	4
DI	1 1 1 1 0 0 1 1	Disable Interrupt	4
NOP	0 0 0 0 0 0 0 0	No-operation	4
HLT	0 1 1 1 0 1 1 0	Halt	7

NOTES:

1. DDD or SSS: B = 000, C = 001, D = 010, E = 011, H = 100, L = 101, Memory = 110, A = 111.
2. Two possible cycle times (6/12) indicate instruction cycles dependent on condition flags.

*All mnemonics copyright © Intel Corporation 1977